

EVA-LAST

INSPIRED BY NATURE, DESIGNED FOR LIFE.



Sustainable Building Materials Product Brochure



www.eva-last.net.au



ITI Australia

Innovative Timber Ideas

itiaustralia.com.au

Pioneer

REAL WOOD REPLICATED IN A REINFORCED PVC COMPOSITE

The Pioneer range is advancing composite aesthetics with high-resolution digital replications of real timbers for an exceptionally natural look and brings a touch of affordable luxury to your outdoor space. A foamed-PVC and glass fiber-reinforced core provides increased strength and span capability and reduces expansion and contraction of the PVC. Its advanced wear layer protects against fading, scratches, and stains while its long-lasting composition resists insects, moisture, and weather-related issues. Enjoy the look of expensive exotic timber in long-lasting and low-maintenance composite.

GFR | GLASS FIBER REINFORCED



PRODUCT COMPOSITION

Pioneer

Pioneer offers a reinforced core and a photorealistic print surface finish with a clear outer wear layer which provides extra protection for the colour and resiliency of the board.

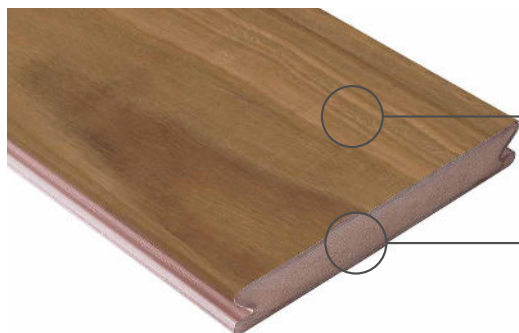

Capping material:

Print surface finish with protective wear layer

Core material:

Foamed-PVC with glass fiber-reinforced core

GFR | GLASS FIBER REINFORCED





TAKE HOME THE BENEFITS



REALISTIC AESTHETIC

Advanced digital replication of real wood for an exceptionally natural look



ECO-FRIENDLY

Prevents deforestation by capturing the beauty of real timbers without felling



AFFORDABLE LUXURY

Enjoy the look of expensive real woods in long-lasting composite



INCREASED SPAN

Reinforced for improved strength & span capability



MORE STABLE

Less movement from expansion & contraction



WEAR LAYER

Wear layer offers protection against stains, scratches and fading



DECAY RESISTANT

Long-lasting & resists insects, moisture, & weather



LOW-MAINTENANCE

Only basic care required for optimal longevity

REAL WOOD REPLICATED IN A REINFORCED PVC COMPOSITE



145 x 21 mm
Grooved both sides

GFR | GLASS FIBER REINFORCED

GROOVED BOARD

The Pioneer wide single sided grooved board is available in a wider, thinner, and lighter profile design. It is reinforced and offers a flawless, fastener-free final look due to grooves along its edges which are designed for streamlined installation using HULK hidden fastener clips, available as S-Series clips or as Chain collated clips.

Dimensions	145 x 21 mm (5.45 m lengths)
Weight	2.2 kg/m
Recommended Joist spacing	450 mm centre to centre* <i>*Please refer to the technical documents for more information on spans and loads.</i>

Grooved board



Fasteners



Compatible with Chain collated clips

PLEASE DOWNLOAD OUR LATEST TECHNICAL GUIDES



Technical Data Sheet



Installation Guide



145 x 21 mm
Starter profile

GFR | GLASS FIBER REINFORCED

STARTER BOARD

The Pioneer wide single sided starter board is lighter weight and ideal for creating a picture frame effect for decks and for use on stairs edges. It simplifies installation by accommodating grooved boards while offering a solid square outside edge. Install using HULK hidden fastener clips on the grooved edge and HULK colour matching top fixing screws on the square edge.

Dimensions	145 x 21 mm (5.45 m lengths)
Weight	2.6 kg/m
Recommended Joist spacing	450 mm centre to centre* <i>*Please refer to the technical documents for more information on spans and loads.</i>

Starter board



Fasteners



Compatible with Chain collated clips



Uses HULK composite top fixing screws on non-grooved edges



Featured: Pioneer, Blackbutt

PIONEER COLOUR GUIDE

Pioneer

The Pioneer colour range celebrates the beauty of timber with exceptionally natural looking composite. Pioneer offers state-of-the-art high-resolution digital print technology and scans of real timber to give each board an unrepeated realistic wood grain texture. This technology mirrors the hues and tones of specific timber types.

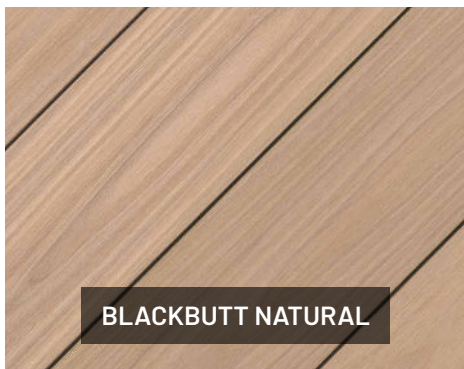

BLACKBUTT NATURAL

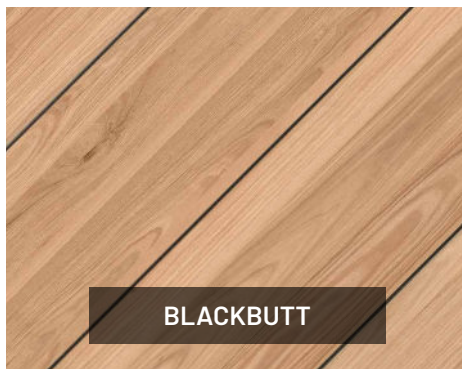

BLACKBUTT

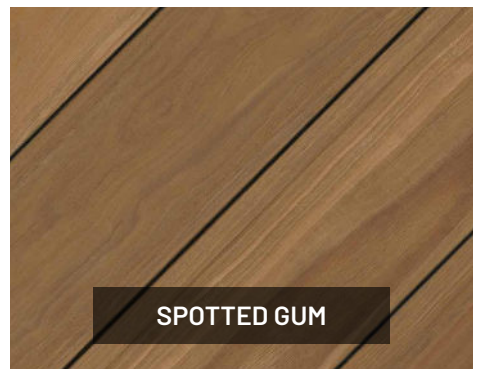

SPOTTED GUM

Pioneer is produced with random colour variations within the product to mimic that of natural timber. So in any colour, you will get a variety of lighter and darker tones just as nature intended. This only adds to the aesthetic appeal of your composite decking.

Apex PLUS

BETTER PERFORMING, BETTER LOOKING COMPOSITE

Apex PLUS takes the benefits of Apex composite to the next level. It offers the natural look of Apex in cutting-edge composite technology. Its improved foamed-PVC and glass fiber-reinforced core creates a more durable and versatile board with increased span capabilities and greater stability. This eco-friendly and slip resistant composite is low maintenance and faces Mother Nature's toughest conditions with reliable long-term performance and timeless style.

GFR | GLASS FIBER
REINFORCED

PRODUCT COMPOSITION

Apex PLUS

Apex PLUS upgrades your outdoor space with a cutting-edge composition that is equally beautiful and resilient. Its reinforced core gives you greater design freedom by reducing the amount of substructure your project needs and its specialised composition minimises contraction and expansion for a more stable board.

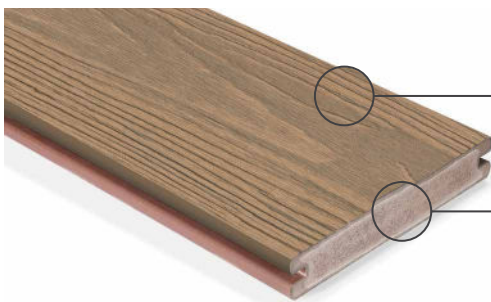

Capping material:

Engineered acrylic polymer

Core material:

Foamed-PVC composite with
glass fiber-reinforcement

GFR | GLASS FIBER
REINFORCED





TAKE HOME THE BENEFITS

Apex PLUS



INCREASED SPAN

Reinforcement improves strength & span capability



MORE STABLE

Less movement from expansion & contraction



NATURAL AESTHETIC

Advanced technology for more natural looking composite



P5

SLIP RESISTANT

Reliable slip resistance properties



LOW-MAINTENANCE

Only basic care required for optimal longevity



PROTECTIVE CAP

Fade, scratch, & stain resistant capping technology



DECAY RESISTANT

Resists insects, moisture, & weather



ECO-FRIENDLY

Long-lasting & prevents deforestation

Apex PLUS



REINFORCED, CAPPED PVC COMPOSITE



190 x 24 mm
Grooved both sides



190 x 24 mm
Rectangular profile

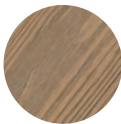

SCULPTED GRAIN

GFR / GLASS FIBER
REINFORCED

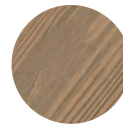

SCULPTED GRAIN

GFR / GLASS FIBER
REINFORCED

GROOVED BOARD

The Apex PLUS single sided grooved board in foamed-PVC with a glass fiber-reinforced core offers a flawless, fastener-free final look thanks to the grooves along its edges which are designed for streamlined installation using HULK hidden fastener clips.

Dimensions	190 x 24 mm (5,45m lengths)
Weight	3.84 kg / m
Recommended Joist spacing	Up to 450 mm on centres

Grooved board

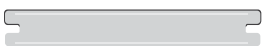

Fasteners



Compatible with
S-Series clip



Compatible with
Chain collated clips

SQUARE EDGE BOARD

The Apex PLUS single sided starter board in foamed-PVC with a glass fiber-reinforced core is designed for use as decking and stair edges. Install using HULK hidden fastener clips on grooved edges and HULK colour matching top fixing screws on square edges.

Dimensions	190 x 24 mm (5,45m lengths)
Weight	3.98 kg / m
Recommended Joist spacing	Up to 450 mm on centres

Square edge board

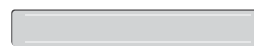

Fasteners



Uses HULK composite
top fixing screws
on non-grooved edges

Please refer to the Apex colours page to see our full colour range.



APEX PLUS DUAL TONE COLOURS

Apex PLUS offers a carefully crafted dual tone colour range which adds an extra layer of colour to each board to embrace the nuances found in timber and enhance the natural look of your project.



SURFACE FINISH



Sculpted Grain Finish

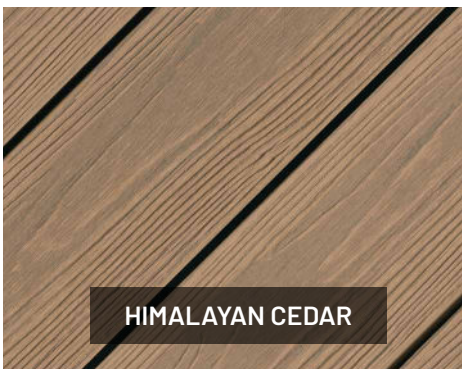

HIMALAYAN CEDAR

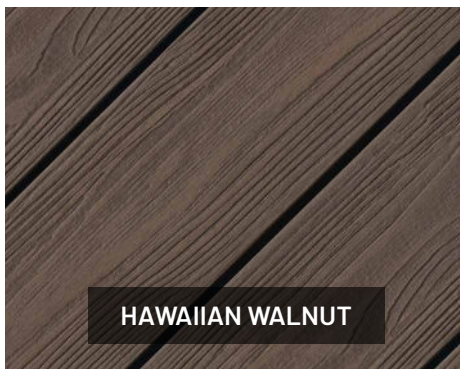

HAWAIIAN WALNUT

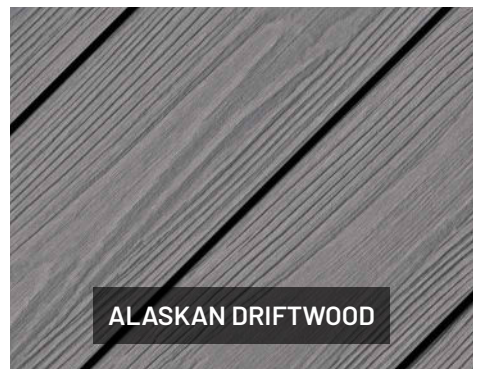

ALASKAN DRIFTWOOD

Apex PLUS is produced with random colour variations within the product to mimic that of natural timber. So in any colour, you will get a variety of lighter and darker tones just as nature intended. This only adds to the aesthetic appeal of your composite decking.

Infinity **IS**

CUT COST, NOT QUALITY

Infinity IS combines all the benefits of durable Infinity composite with the advantages of I-Series to give you a durable co-extruded composite offering low maintenance, and an advanced resilient polymer cap for protection against scratches, fading, moisture issues, decay, and weather, as well as stain and slip resistance. With Infinity IS specialised streaked colour variation technology you can enjoy the look of timber in an environmentally friendly composite deck. The revolutionary I-beam design creates a cost-effective, lightweight board that uses less material, yet maintains span capabilities, strength, and stiffness for a more efficient installation. This improved environmentally friendly composite is holistically sustainable from its manufacturing to its use of raw material.



PRODUCT COMPOSITION



I-Series offers a cost-effective, lightweight decking option thanks to its revolutionary shape which uses less material but maintains class-leading strength, stiffness, and span capability.



(P) PATENTED TECHNOLOGY

Capping material:
Engineered polymer

Core material:
PE composite



COST-EFFECTIVE
Smart shape saves on transport & installation



LIGHTWEIGHT
I-beam design is lighter by using less material



SPAN
Span capability of heavier boards



INSTALLATION
Easier and more efficient installation





TAKE HOME THE BENEFITS

Infinity



DURABLE

One of the toughest co-extruded composites



PROTECTIVE CAP

Fade, scratch, & stain resistant capping technology



LOW-MAINTENANCE

Only basic care required for optimal longevity



DECAY RESISTANT

Resists insects, moisture, & weather



STAIN RESISTANT

Built-in protection against stains



SLIP RESISTANT

Reliable anti-slip protection



NATURAL LOOK

Specialised streaked colour technology



ECO-FRIENDLY

Sustainable manufacturing & use of raw material

LIGHTWEIGHT, CAPPED COMPOSITE DECKING



135 x 25.4 mm
Grooved
both sides



135 x 25.4 mm
Grooved
one side



SCULPTED GRAIN



SCULPTED GRAIN

GROOVED BOARD

The Infinity IS single sided grooved board installs efficiently and securely with HULK hidden fastener clips which slot into the grooves along the edges of the board and create a neat uninterrupted final look.

Dimensions	135 x 25.4 mm (5,45m lengths)
Weight	2.84 kg / m
Recommended Joist spacing	Up to 450 mm on centres

Grooved board



Fasteners



Compatible with
S-Series clip



Compatible with
Chain collated clips

STARTER BOARD

The Infinity IS single sided starter deck board offers one grooved edge and one solid edge, making it perfect for deck perimeters, picture framing decks, and creating stair edges. It fastens with a combination of HULK hidden fasteners and colour matched HULK composite decking screws.

Dimensions	135 x 25.4 mm (5,45m lengths)
Weight	2.7 kg / m
Recommended Joist spacing	Up to 450 mm on centres

Starter board



Fasteners



Compatible with
S-Series clip



Compatible with
Chain collated clips



Uses HULK composite
top fixing screws
on non-grooved edges

Infinity



CAPPED COMPOSITE FASCIA



150 x 12mm
Fascia board



SCULPTED GRAIN

FASCIA BOARD

The Infinity single sided fascia boards are non-load bearing profiles that add a neat finish to deck edges or areas where trim is needed. They are neatly fastened by top fixing colour matching HULK composite trim screws.

Dimensions	150 x 12 mm (4.8 m lengths)
Weight	2.3 kg / m
Recommended Joist spacing	Up to 450 mm on centres

Fascia board



Fasteners



Uses HULK composite top fixing screws



Scan to view the Infinity Installation Guide



Please refer to the Infinity IS colours page to see our full colour range.





SCULPTED GRAIN SURFACE FINISH COLOUR GUIDE

Infinity composite offers incredibly natural-looking colours thanks to its advanced colour technology which gives each board unique colour variation to embody the essence of timber. Enjoy the beauty of wood with the benefits of composite.

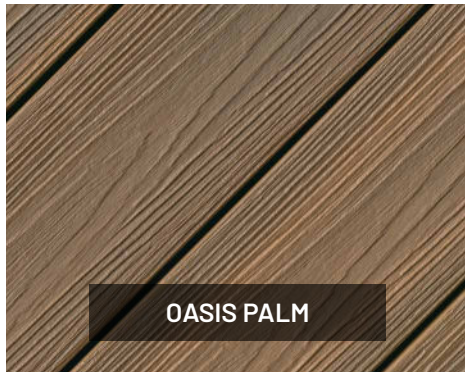
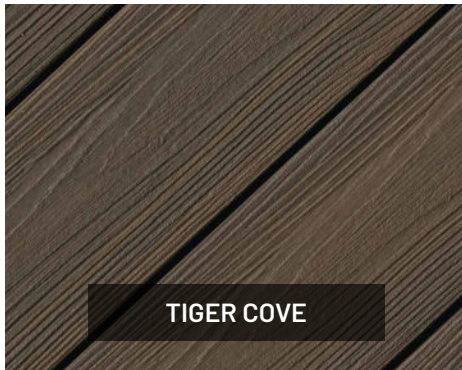
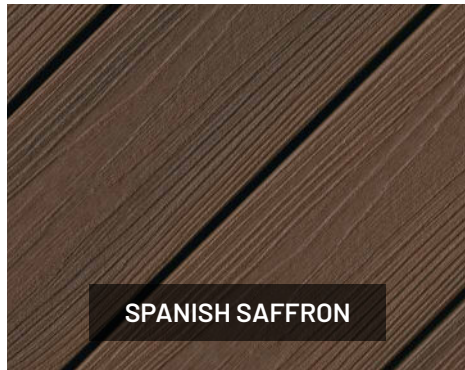
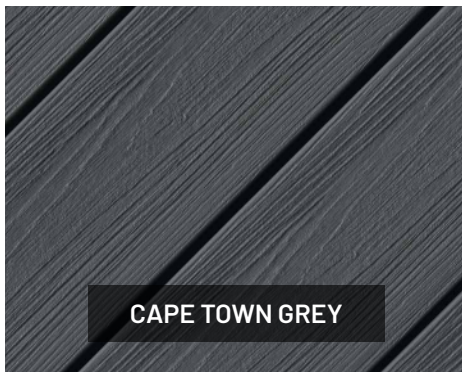

Infinity IS is produced with random colour variations within the product to mimic that of natural timber. So in any colour, you will get a variety of lighter and darker tones just as nature intended. This only adds to the aesthetic appeal of your composite decking.

CAPPED COMPOSITE SCREENING



SCREEN BOARD

The Infinity screen board is a thin, lightweight composite profile. This double sided board offers a brushed finish on both faces of the profile to create a neat aesthetic for cladding or screening. HULK top fixing screws securely fasten the board in place and are available in colours to match the composite boards for a seamless look.

Dimensions	70 x 16 mm (5,4 m lengths)
Weight	1.4 kg / m
Recommended Joist spacing	1200 mm when fixed to 3 or more supports 900 mm when between 2 supports



BRUSHED SOFTWOOD

Screen board



Fasteners



Uses HULK composite top fixing screws

INFINITY BRUSHED SOFTWOOD SURFACE FINISH COLOUR GUIDE

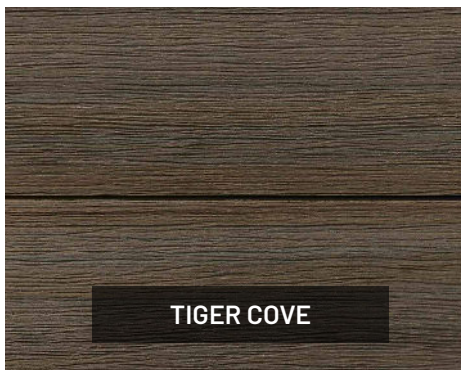
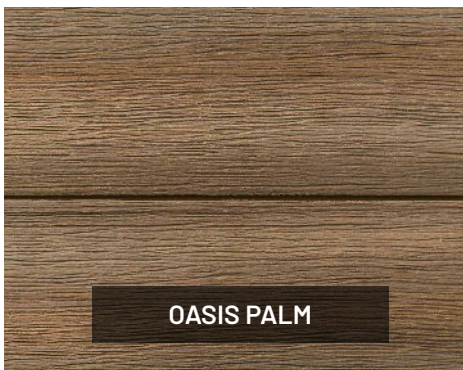

Infinity is produced with random colour variations within the product to mimic that of natural timber. So in any colour, you will get a variety of lighter and darker tones just as nature intended. This only adds to the aesthetic appeal of your composite decking.





ADVANCED COMPOSITE CLADDING

The VistaClad lightweight composite cladding system is revolutionising how cladding works with an innovative clip strip which locks boards into place using reliable dual spring technology. VistaClad is available in a range of colours and finishes, with trim and accessories, as a complete cladding system, designed for ease of installation. Backed by an industry-leading warranty, this low-maintenance, weather-resistant cladding is a smart, cost-efficient investment in your project, and a sustainable investment in our planet.



VISTA CLAD SYSTEM COMPONENTS

The VistaClad system combines Eva-Last composite technologies with an innovative installation process to provide a robust and convenient cladding solution. The resultant hidden fixing generates an unblemished finish and avoids the limitations or inconvenience of fastening through composite.



Composite Cladding Boards



Clip Strips



Adapters and Trim Profiles

CUTTING-EDGE SUSTAINABLE CLADDING

VistaClad composite cladding breathes vibrancy into your home or office space and enhances your walls with the attractive look of hardwoods. Let routine maintenance and premature replacement be things of the past as you look to the future with one of the most cutting-edge, and durable cladding products available. VistaClad is available in a selection of natural looking colours and comes with a complementary trim solution for a neat and tidy finish.



TAKE HOME THE BENEFITS



CLIP LOCK DESIGN

Boards securely click & lock into place to withstand strong winds



COMPLETE CLADDING SOLUTION

Innovative system with concealed fastening & trim for a finished look



LIGHTWEIGHT

Smart system engineered for lighter weight & better airflow



VENTILATED & INSULATED

Design allows for system ventilation & natural insulation



LOW-MAINTENANCE

Ideal for large-scale projects & application at height



DECAY RESISTANT

Resists biodegradation, corrosion, insects, UV, & harsh weather



COST-EFFECTIVE SYSTEM

Save on fast, simplified installation & overall upkeep



ECO-FRIENDLY

Sustainable manufacturing & use of raw materials

VISTA CLAD CLADDING IN APEX PVC COMPOSITE

VistaClad is available in Apex PVC composite. Backed by a 30-year warranty, Apex lightweight, capped composite is an ideal cladding material. The dual colour finish of Apex provides an exceptionally natural looking composite which embodies the essence of timber in a range of nuanced shades to complement your overall project. Install this environmentally friendly, low-maintenance cladding vertically or horizontally to suit your style.

Apex



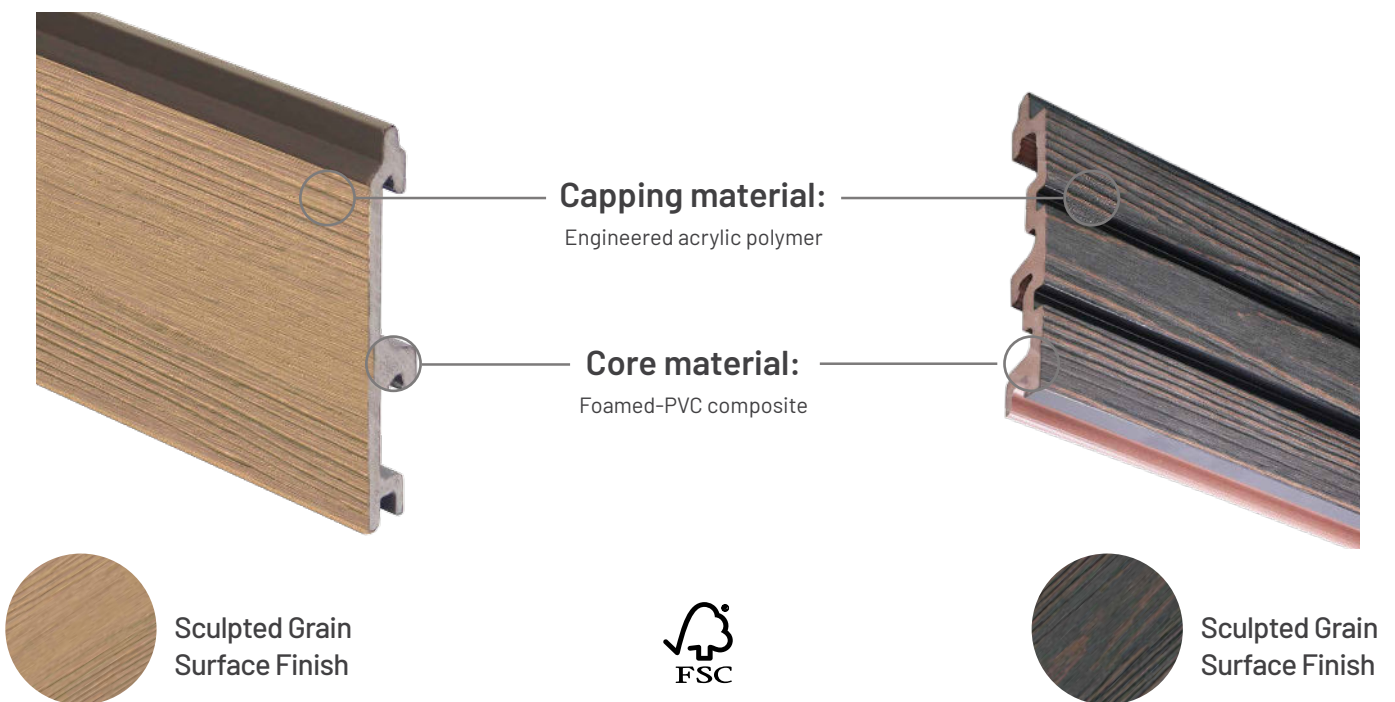

PVC COMPOSITE CLADDING MATERIAL



APEX FOAMED-PVC CLADDING PROFILES

Multi-width, multi-depth Apex sizes

Cross section	Product description	Dimensions	Coverage	Mass
	Flat	163 x 24.5 mm	6.6 m ² /m	1.4 kg/m
	Two grooves	163 x 24.5 mm	6.6 m ² /m	1.6 kg/m



TECHNOLOGY: **Apex**

VISTA CLAD IN APEX DUAL TONE COLOUR TECHNOLOGY

The Apex dual tone colour range offers a sculpted grain finish for more natural looking cladding. Each cladding board has an extra layer of colour added to create the subtle variances found in timber. The sculpted grain finish produces a texture that embodies the look of wood to give your exterior walls the beauty of timber cladding in a more resilient, low-maintenance, and eco-friendly composite option.



Sculpted Grain
Surface Finish





THE CLIP STRIP

The VistaClad clip strip uses a punched spring design that allows the cladding boards to be easily and securely clicked into place. Three epoxy-coated, zinc-galvanised strip profile options provide flexibility in application and allow for optimal ventilation and drainage.

The dual spring-loaded clip creates a rigid hold and locks the boards in place.



FLAT CLIP STRIP

The flat clip strip is fitted directly to the wall substrate or frame. As a result, this solution provides the smallest ventilation/drainage cavity and fixing can only be done through the face of the clip strip.

Dimensions	40 x 11.7 mm (1.8 m lengths)
Weight	0.4 kg/m



TOP HAT CLIP STRIP

The top hat clip strip fits over 38 mm (timber) and 40 mm (composite and steel) supports. As a result, the ventilation/drainage cavity will be influenced by the thickness of the support as well as the fixing method but the minimum depth the top hat profile allows for is 25.4 mm. Fixing can be done through the face, the side, and either side of the clip strip base. Fixing through the side allows for the top hat to be plumbed quickly and easily.

Dimensions	85.4 x 35.9 mm (2.7 m lengths)
Weight	1.2 kg/m



NYLON ADAPTORS

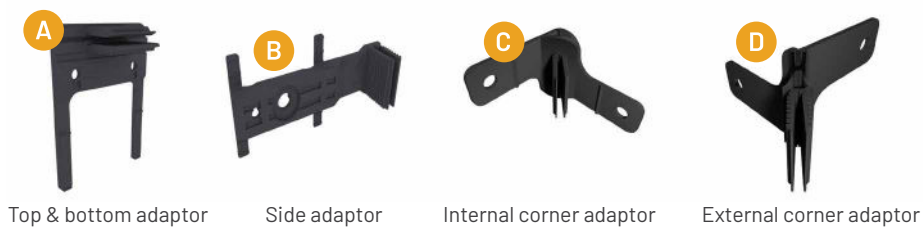

ALUMINIUM TRIM PROFILES

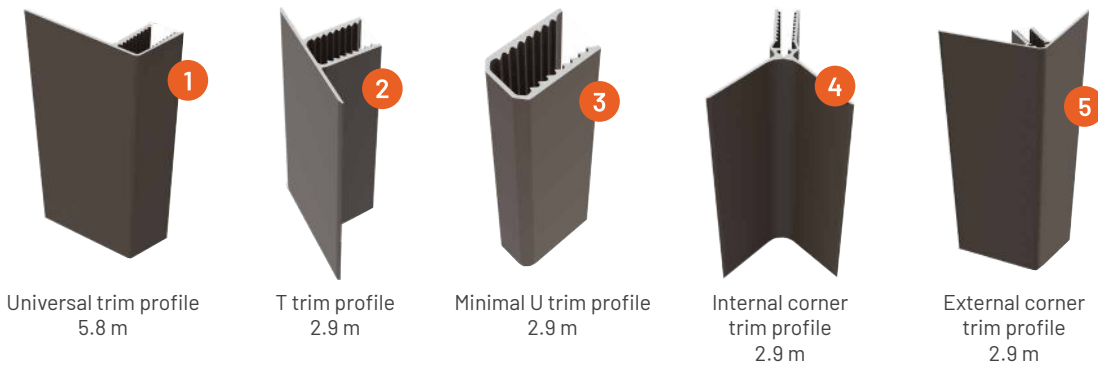

AVAILABLE TRIM COLOURS:

- Black
- Brown
- Tan Brown
- Light Tan

TRIM APPLICATIONS

Trim accessories hide the structure for a neat final look and can be installed using sealing strips to improve the weather resistance of the cladding surface. The clip strip allows for easy guided placement of the adaptors and the universal trims may be used with VistaClad or any cladding boards with a thickness of 20.5 to 26.5 mm.

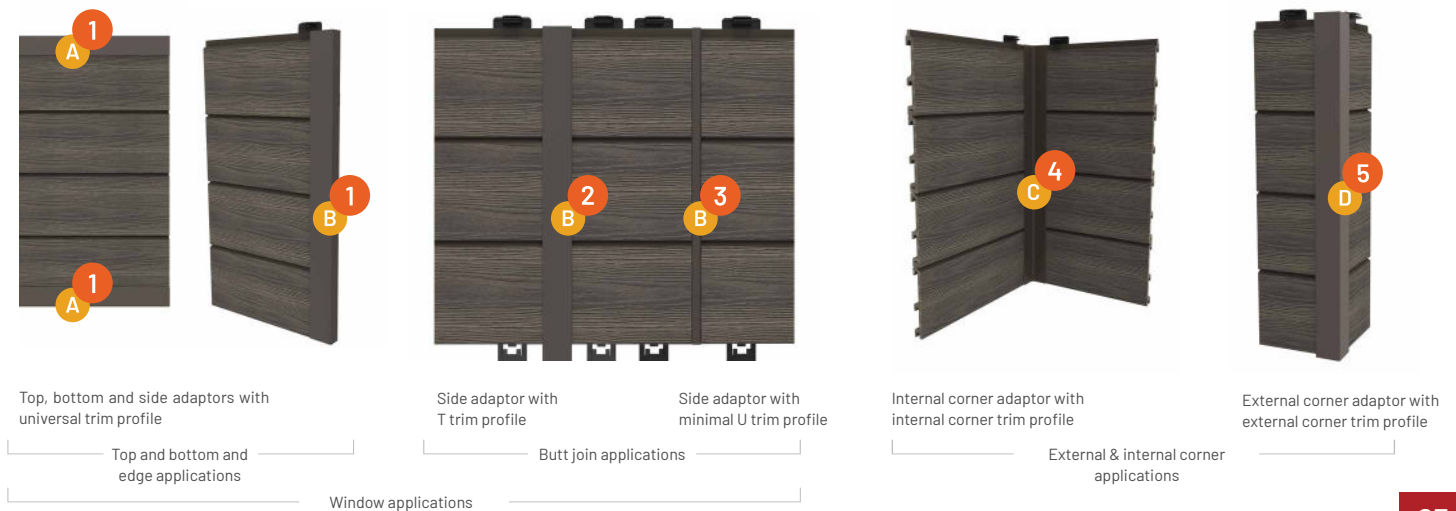

HULK FASTENERS.

FASTENED, FOR LIFE.



Corrosion
Resistant



Colour Matched
Aesthetic



Neat Surface
Finish



Fast and Easy
Installation



No Pre-drilling
Required

DESIGNED FOR PROFESSIONALS. PERFECT FOR NOVICES.

Eva-Last has developed a range of fasteners that thoroughly complement our composite products to ensure the stability and longevity of your deck. HULK fasteners are specially designed to securely fasten the deck boards to a substructure, but can also be used in other wood or steel fixing applications. The coating employed for our HULK fasteners ensures the fixing system supports your deck through out its lifespan.

HULK FASTENERS				
IMAGE	COLOUR	BITS	MATERIAL	UNITS PER PACK
<p>HALO CLIP (S9)</p>	Black	N/A	Stainless Steel 430	125 & 350
<p>SCREW FOR TIMBER</p>	Black	T 15	Stainless Steel 316	
<p>SCREW FOR METAL</p>	Black	T 15	Carbon Steel C1022	
<p>CDS SCREW</p>	Light Grey Dark Grey Beige Tan Brown Light Brown Brown	TX 20	Stainless Steel 316	75
<p>MDS SCREW</p>	Light Grey Dark Grey Beige Tan Brown Light Brown Brown	TX 20	Carbon Steel C1022	75

HULK FASTENERS COLOUR GUIDE

HULK timber and metal frame deck screws are specifically designed for fastening composite decking securely to the deck frame. Countersinking heads are coloured to match your deck to leave a neat surface finish.









COMPOSITE DECK SCREW **CS**
FOR TIMBER FRAMES **SS**



METAL DECK SCREW **CS**
FOR TIMBER FRAMES

Use the table below to help choose the HULK Fasteners screw that best matches your Eva-Last decking or decking of similar color.

COLOUR	PIONEER	APEX PLUS	INFINITY
 LIGHT GREY	-	-	Caribbean Coral
 DARK GREY	-	Alsakan Driftwood	Cape Town Grey
 BEIGE	Natural Blackbutt Blackbutt	Himalayan Cedar	-
 TAN BROWN	Spotted Gum	-	-
 LIGHT BROWN	-	Hawaiian Walnut	Oasis Palm Spanish Saffron
 BROWN	-	-	Tiger Cove

CS C1022
CARBON STEEL

SS SS316/SS410
STAINLESS STEEL

chain

Collated decking clip

A PRODUCT BY **HULK FASTENERS.**

GET THE JOB DONE FASTER.

Chain collated clips save you time and money by streamlining installation with pre-loaded screws that offer cutting-edge performance for the entire lifespan of your deck. Enjoy a simpler installation and a more secure long-term fastener that complements the overall look of your deck.

Stainless steel clip with polymer coating

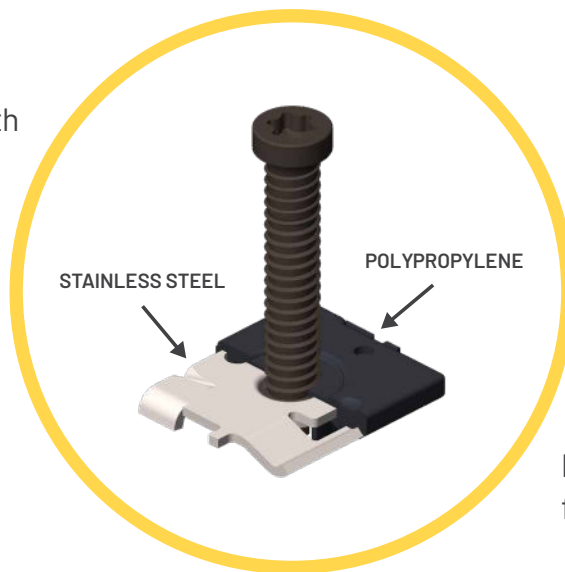

Pre-loaded with screw for ease of installation

FEATURES AND BENEFITS



MORE EFFICIENT INSTALLATION

Collated system comes pre-loaded with screws for quicker installation



DURABLE

Stainless steel clip with a protective polymer coating for extended outdoor longevity



INNOVATIVE ENGINEERING

Cost-effective use of materials without affecting grip strength or overall clip performance



UNIVERSAL APPLICATION

Works with timber & composite boards of variable thickness & groove depths



STRENGTH IN SIZE

Proven strength in uplift holding power & preventing lateral movement of boards



EASIER POST-INSTALLATION ACCESS

More convenient post-installation board removal with direct overhead fastener access

CHAIN COLLATED CLIPS

Chain collated clips offer a smarter solution for creating an outdoor oasis. By preloading high quality and durable screws into equally reliable clips. Chain collated clips make installation more efficient, and are suitable for use by professionals or novices. Like all Eva-Last products, Chain collated clips are built on the principle of longevity.

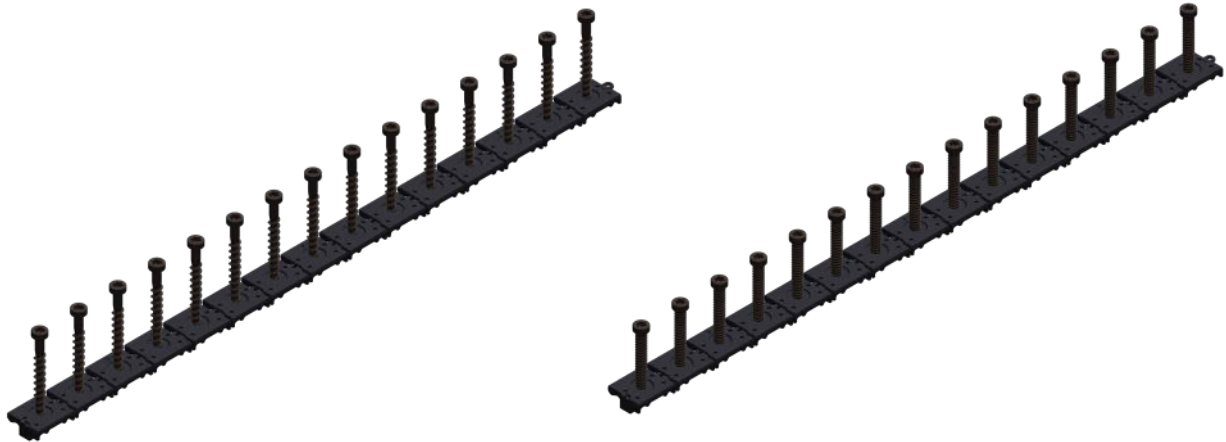

Collation with screw for timber frames

Collation with screw for metal frames

CHAIN HAND TOOL

The Chain hand tool adds value to the Chain collated clip system by maximising installation efficiency. The hand tool creates precise fastening thanks to its built-in depth control system that eliminates installation errors and weak connections. The hand tool is compatible with a wide range of composite and timber board sizes, ergonomically designed for ease of use, and made from high quality materials for long-lasting reliability.

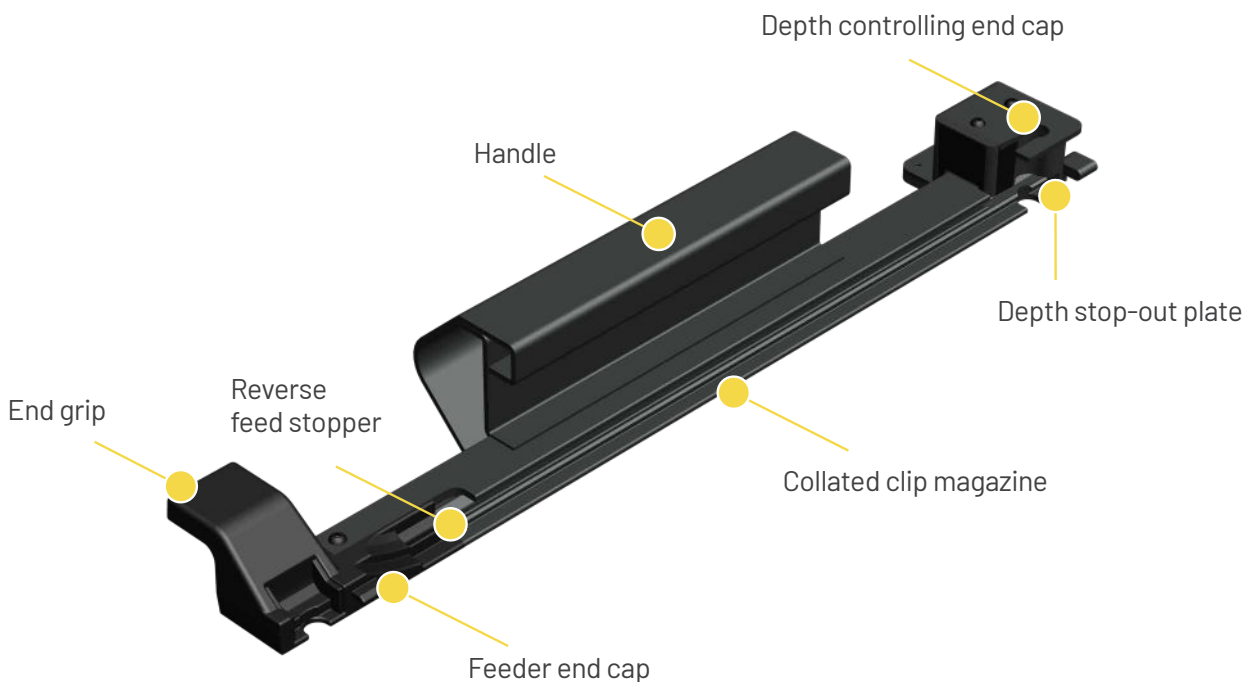



LOW ENVIRONMENTAL IMPACT

Holistically sustainable manufacturing & use of raw materials

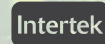

CHOOSE SUSTAINABLE BUILDING MATERIALS



The mark of responsible forestry

RENEWABLE RESOURCES & RENEWABLE ENERGY

We believe that how we manufacture is just as important as what we manufacture when it comes to going green. That's why we've traded in fossil fuels for renewable energy. Our products use solar power as part of our manufacturing process. We are fully committed to bringing you a product that's holistically sustainable.

Eva-Last is internationally recognised for our commitment to the environment. We're proud of the work we do to promote environmental sustainability, and invite you to choose timber alternatives that are gentle on the Earth.

- Made from recycled materials
- No trees felled
- No treatment or toxic chemicals required for maintenance
- Solar power used in the manufacturing process
- Reduced impact on landfills
- Reduced carbon footprint

Proudly distributed in Australia by



saleswa@iti.net.au

ITI WA (Perth) - Tel: 08 9256 5700

102-108 Bannister Rd, Canning Vale, WA 6155



www.eva-last.net.au

Eva-Last reserves the rights to all brands, products and trademarks within this publication.
Eva-Last ITEM: 0324 V1 WA-DECKING BROCHURE

Disclaimer:

Although we make every effort to ensure the information contained in this brochure is accurate, we are NOT responsible for any errors or misprint that occurs and we are NOT responsible for ANY damage or liability that result from the use (or misuse) of the information. In the event that an error does occur, we reserve the right to correct, or make changes to, this information at any time.

Disclaimer:

Span data provided herein is indicative based on specific test load conditions (refer to your product Technical Data Sheet). Dimensional and mass data provided herein is indicative based on typical production and may vary with manufacture and material tolerance. Before installing any Eva-Last product, ensure that the application is rational and complies with the local regulations and building codes. Wherever necessary, consult a suitably qualified professional.